

Trigeneration units on carbon dioxide with two-time overheating with installation of turbo detainer and recovery boiler

A V Ovsyannik, P A Kovalchuk, A I Arshukov and V P Klyuchinsky

Sukhoi State Technical University of Gomel,
Republic of Belarus, 246746 Gomel, October Ave., 48

ovsyannik@tut.by

Abstract. The schemes of a carbon dioxide trigeneration plant using secondary energy resources in the form of products of combustion or flue gases and a combined cycle gas turbine unit (CCGT) with a recovery boiler, which simultaneously produce electricity, heat and cold for centralized and decentralized supply of consumers, are presented. In addition, the production of liquid and gaseous carbon dioxide is possible. The main elements of the plants are a heating unit, a gas turbine unit with a recovery boiler, a turboexpander unit and a carbon dioxide unit for the production of cold, liquid and gaseous carbon dioxide. A thermodynamic calculation and a brief exergy analysis of the plants were carried out.

1. Introduction

Currently, more and more attention is paid to the search for the most efficient and safe working fluids for power plants of direct and reverse cycles. One of these working fluids is natural refrigerants and, in particular, carbon dioxide. The point of view about the dangers of freons and the benefits of natural refrigerants is now dominant both in the EU and in the world. All large European companies have long included CO₂ refrigeration systems in their technical specifications and design decisions, and now, several years after the first successful implementation of such plants, large companies are replicating previously worked out solutions [3].

In practice, this means that, when they enter the markets of various countries, companies bring with them the technical solutions that have been tested in Europe, among which is CO₂ [3]. Although a number of technical problems arise when using carbon dioxide, there are solutions to them. Even 100 years ago, they were able to cope with “parking pressure” and were not afraid of a “critical point” [3]. Do not be afraid of this now. One can definitely hope that CO₂ systems, as their number grows and freon components are phased out, become cheaper than freon analogues and, just as importantly, become more environmentally attractive and safe [3].

The main advantages of using CO₂ in refrigeration compared to HFC refrigerants are their efficiency, safety, environmental friendliness and low cost, as well as compliance with the latest trends in legislation [2].



Speaking about the advantages of CO₂, it is important to note that this refrigerant also has a number of features. Unlike traditional CO₂ refrigerants, in addition to a higher operating pressure range, it has a high critical and low triple point. The triple point of CO₂ (−56.6 ° C; 5.2 bar), in practice related to the precipitation of “dry ice”, should be considered when installing and maintaining the system. Taking into account the critical point of CO₂ (+31.1 ° C; 73.6 bar) is important both for maintenance and for the design of carbon dioxide systems.

Depending on the purpose and type of systems, the design CO₂ pressures can vary from 40 to 140 bar. Moreover, subcritical systems are used in industrial cold, and both subcritical and transcritical installations are popular in the commercial cold [3].

Carbon dioxide can also be used as a standalone refrigerant. Compressor-condensing units in this case work with greater efficiency than Freon units in cold and temperate climates. All three options, i.e. direct cooling systems on hydrocarbons, systems with an intermediate refrigerant carrier and vapor compression systems on CO₂ are technically feasible, which is confirmed by their successful implementation in industry [2, 3].

2. Investigated schemes and analysis of the results

The advantages of CO₂ over HFC refrigerants such as efficiency, safety, environmental friendliness, low cost and compliance with the latest trends in legislation are considered in [2].

Based on the considered energy, technical and environmental prerequisites for the use of CO₂ in power plants for generating electric, thermal energy and cold, it is proposed to use carbon dioxide to produce these types of energy in the expander cycle. A distinctive feature of this installation is that only one refrigerant is used - CO₂.

The scheme of a carbon dioxide trigeneration plant for secondary energy with the production of liquid and gaseous carbon dioxide is shown in Figure 1.

The principle of operation of the proposed installation is based on the use of the heat of the exhaust products of combustion (metallurgical, glass melting furnaces, boiler units, etc.) in order to increase the energy efficiency of thermal power plants and reduce their heat loss. In addition, the environmental problem of capturing carbon dioxide and preventing its release into the environment is being addressed. The proposed installation can operate on secondary energy resources, which are currently used in extremely limited quantities.

The installation is connected through a heating unit, consisting of two heat exchangers 24 and 25, to a source of combustion products or flue gases. In heat exchangers of the heating unit, they are cooled to the required temperature, after which the combustion products enter sequentially in the absorber 2 with absorption of gaseous carbon dioxide from the combustion products and stripper 3, where CO₂ is extracted from the absorbent. After the stripper, carbon dioxide enters through the spray separator 4 and desiccant 5 into the injector 6, where it is injected into the linear receiver 7, while its pressure rises to the suction pressure in the compressor of the first stage 8. After the three-stage compressor 8, gaseous CO₂ is sent to the condenser 9, liquefied and supplied the first throttling to the throttle device 20, after which the temperature and pressure of CO₂ are reduced, and then to the separator 22. The liquid CO₂ phase separated in the separator is fed to the second throttling to the throttle device 21, where again the temperature and pressure decrease. Liquid carbon dioxide from the separator 23 is supplied to the condenser 13 of the turbogenerator unit, boils, absorbing the heat of condensation of gaseous CO₂ after expansion in the turboexpander 12. The gas formed as a result of boiling CO₂ is directed to the injector 6, injects gaseous CO₂ after the stripper 3 and accumulates in the linear receiver 7 Part of the liquid carbon dioxide after the separator 22 is

supplied to the condenser 9 to condense the compressed gaseous CO₂ after the compressor 8. The heat exchangers 24 and 25 of the heating unit are designed to heat the mains water for heating and hot water supply.

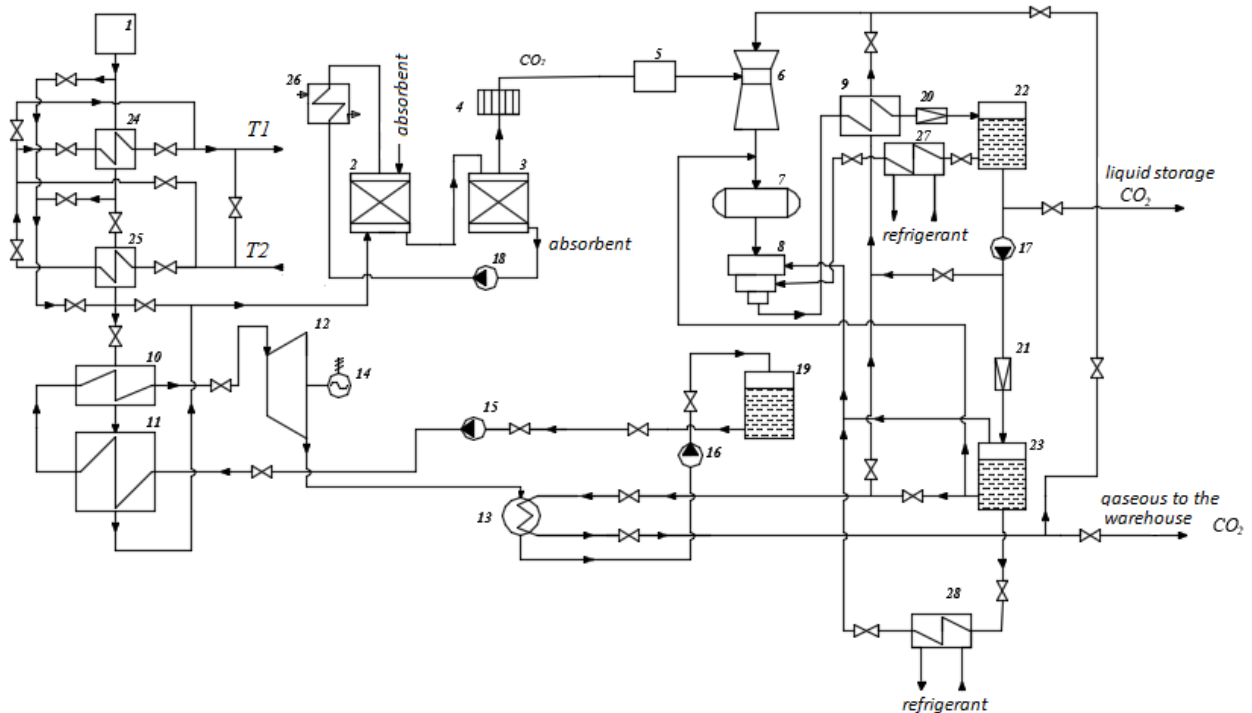

Figure 1. Diagram of a trigeneration turboexpander plant for secondary energy with the production of liquid and gaseous carbon dioxide: 1 - source of combustion products (VER); 2 - an absorber; 3 - stripper; 4 - spray separator; 5 - desiccant; 6 - injector; 7 - receiver; 8 - compressor; 9 - capacitor; 10 - superheater; 11 - evaporator; 12 - steam turbine; 13 - capacitor; 14 - electric generator; 15, 16, 17, 18 - pump; 19 - collection; 20, 21 - control valve; 22 - separator 1; 23 - separator 2; 24, 25, 26 - heat exchanger; 27, 28 - the evaporator.

From the receiver-accumulator 19, liquid CO₂ is pumped sequentially by the pump 15 into the evaporator 11 and the superheater 10, where it evaporates and overheats to the required temperature, after which it enters the turboexpander 12, expands, condenses in the condenser 13 and is pumped again to the receiver-accumulator 19 by the pump 16. The turbo-expander circuit (turbo-expander 12 — evaporator 11 — superheater 10 — condenser 13 — pump 16 — receiver – accumulator 19) can operate both on a cycle with subcritical parameters and on a cycle with supercritical (transcritical) parameters. The diagram does not show the cooling of gaseous CO₂ after compression in the first and second stages of the compressor.

Figure 2 shows the theoretical cycles of the expander and carbon dioxide loops in the $\lg p - h$ diagram with complete intermediate cooling.

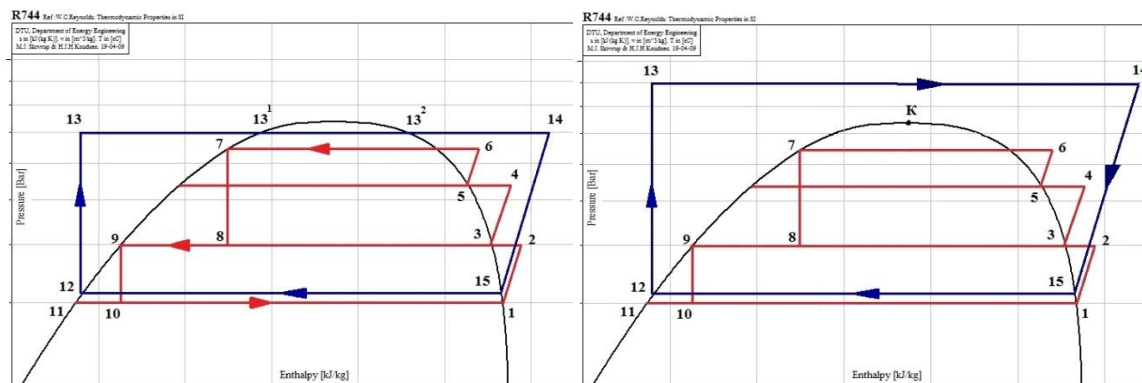

Figure 2. A cycle of a carbon dioxide turboexpander trigeneration plant at the sub- and supercritical parameters of the working fluid.

The cycles consist of the following processes: 12 - 13 - increasing the pressure of liquid CO₂ in the pump 16; 13 - 13¹ - heating of liquid CO₂ to a boiling point in the evaporator 11; 13¹ - 13² - isobaric-isothermal process of boiling CO₂ in the evaporator 11; 13 - 14 - overheating of gaseous CO₂ in the superheater 10; 14 - 15 — adiabatic expansion of gaseous CO₂ in a turboexpander 12; 15 - 12 - isobaric-isothermal process of condensation of carbon dioxide in the condenser 13. For the refrigeration cycle: process 1-2 - adiabatic compression of gaseous CO₂ in the compressor of the first stage; 2-3 - CO₂ cooling in front of the second stage compressor; 3-4 - adiabatic compression of CO₂ in a second stage compressor; 4-5 - intermediate cooling of CO₂ in front of the compressor of the third stage; 5-6 — adiabatic compression of CO₂ in a third stage compressor; 6-7 - cooling and condensation of gaseous CO₂ in the condenser 9; 7-8 - the first adiabatic throttling of liquid carbon dioxide in the inductor 20 into the separator 22; 9-10 - the second adiabatic throttling of CO₂ in the throttle 21 to the separator 23; 11-1 - boiling liquid CO₂ in a condenser-evaporator 13.

When calculating and analyzing the cycle of a turboexpander plant, it is necessary to consider the direct cycle of heat and electric energy generation in the heating circuit and in the turboexpander circuit, and a reverse three-stage cycle for the production of liquid and gaseous carbon dioxide and cold generation. operates at a boiling point T_{01} corresponding to the saturation pressure P_{01} , and the evaporator 28 operates at a boiling point T_{02} corresponding to the pressure P_{02} . Gaseous CO₂ from the separator 22 and the evaporator 27 and from the separator 23 and the evaporator 28 respectively passes to the second and first stages of the compressor 8. Improving and increasing the energy efficiency of thermal power plants is associated with the development and implementation of combined cycle gas turbine units (CCGT) of the utilization type. In this case, in particular, a high value of efficiency for the release of electric energy is achieved.

One of the main directions for improving combined-cycle power plants is the introduction of intermediate superheating of steam (gas), partially spent in a turboexpander [14, 15]. This makes it possible to increase the efficiency of the turboexpander due to the supply of additional heat to the gas, as a result of which the useful heat transfer in the turboexpander increases. This leads to an increase in the electric power of the turbo-expander and an increase in the supply of electric energy. In addition, the degree of dryness of gaseous carbon dioxide on the blades of the last stage of the turboexpander increases, which increases the reliability and durability of its blades.

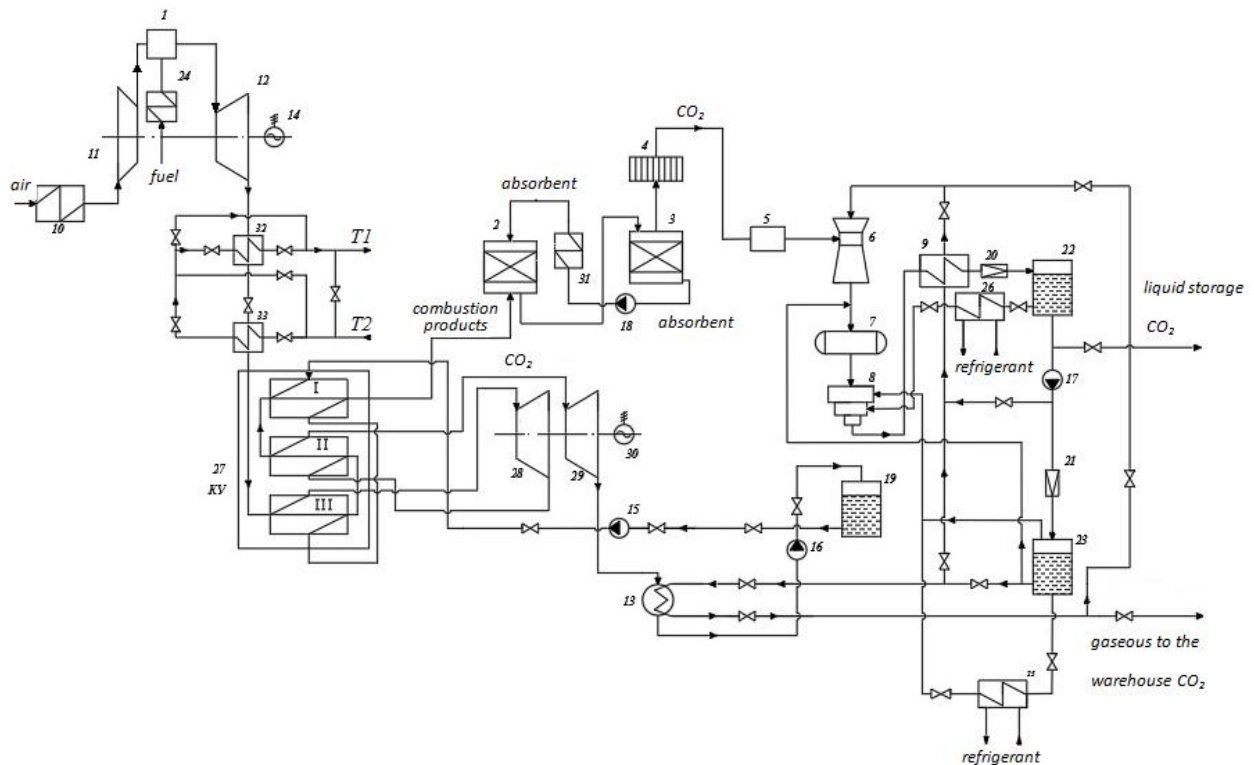

Figure 3. Scheme of a combined cycle gas turbine expansion unit with a waste heat boiler: 1 - combustion chamber; 2 - an absorber; 3 - stripper; 4 - spray separator; 5 - desiccant; 6 - injector; 7 - receiver; 8 - compressor; 9 - capacitor; 10 - air heater; 11 - a turbocompressor; 12 - gas turbine; 13 - condenser-evaporator; 14, 30 - electric generator; 15, 16, 17, 18 - pump; 19 - collection; 20, 21 - control valve; 22 - separator 1; 23 - separator 2; 24, 31, 32, 33 - heat exchanger; 25, 26 - evaporator; 27 - waste heat boiler; 28, 29 - CVP and NPV turbines, respectively;

It should be noted one more circumstance that affects the operation of the combined cycle steam generator with a waste heat boiler. The use of carbon dioxide in turboexpander installations as the working fluid allows vaporization and overheating processes at lower gas temperatures after the gas turbine, which significantly reduces the temperature stresses in the turbine expander blade and increases the reliability and durability of its operation. In addition, a decrease in gas temperature after a gas turbine leads to an increase in the net heat transfer in a gas turbine. At the same time, its electric power increases and the released electric energy of the gas turbine installation increases.

The principle of operation of the installation shown in Figure 3 is as follows: fuel is supplied to the heat exchanger 24, where it is subsequently heated and supplied to the combustion chamber (KS) 1, air is also supplied through the heat exchanger 10 and turbocompressor 11 there. In COP 1, the air-fuel mixture burns and forms flue gases. Flue gases enter the gas turbine 12. An electric generator 14 converts the mechanical energy of rotation of the turbine into electricity. The exhaust flue gases from the gas turbine go to the network heaters 32, 33, then to the waste heat boiler 27 to stage III, where they heat up gaseous CO₂ directed to the turbofan turbine 28. After stage III, the flue gases go to stage II where they heat up gaseous CO₂ directed to Turbine NPP 29. An electric generator 30 converts the mechanical energy of rotation of the turbine shaft into electricity.

After the recovery boiler, the combustion products enter sequentially in the absorber 2 with the absorption of gaseous carbon dioxide from the combustion products and stripper 3, where

CO₂ is extracted from the absorbent. After the stripper, carbon dioxide enters through the spray separator 4 and desiccant 5 into the injector 6, where it is injected into the linear receiver 7, while its pressure rises to the suction pressure in the compressor of the first stage 8. After the three-stage compressor 8, gaseous CO₂ is sent to the condenser 9, liquefied and supplied the first throttling to the throttle device 20, after which the temperature and pressure of CO₂ are reduced, and then to the separator 22. The liquid CO₂ phase separated in the separator is fed to the second throttling to the throttle device 21, where again the temperature and pressure decrease. Liquid carbon dioxide from the separator 23 is supplied to the condenser-evaporator 13 of the turbogenerator unit, boils, absorbing the heat of condensation of gaseous CO₂ after expansion in CVP 28 and NPP 29. The gas formed as a result of boiling is directed to injector 6, injects gaseous CO₂ after stripper 3 and accumulates in the linear receiver 7. A part of the liquid carbon dioxide after the separator 22 is supplied to the condenser 9 to condense the compressed gaseous CO₂ after the compressor 8

From the storage reservoir 19, liquid CO₂ is pumped 15 by the pump 15 to the evaporator I of the recovery boiler 27, where it evaporates, after which it enters the stage III of the recovery boiler 27, where the vaporous CO₂ is overheated and sent to the turbine cylinder 26. After the CVD, the CO₂ flows to stage II of the boiler utilizer 27, where the second overheating takes place, after which CO₂ is fed to the turbo-turbine NPV 29. Then, the CO₂ is condensed in the condenser 13 and pump 16 is again fed into the receiver – drive 19. The turbo-expander circuit (CVP 28 and NPP 29 — the heat recovery boiler 27 — the condenser-evaporator 13 - pump 16 - receiver - accumulator 19) can operate both on a cycle with subcritical parameters and on a cycle with supercritical (transcritical) parameters. The diagram does not show the cooling of gaseous CO₂ after compression in the first and second stages of the compressor.

Secondary overheating of carbon dioxide circulating in the steam-turbine circuit is carried out in a recovery boiler, however, it is possible to overheat in the gas turbine combustion chamber, as shown in Figure 4.

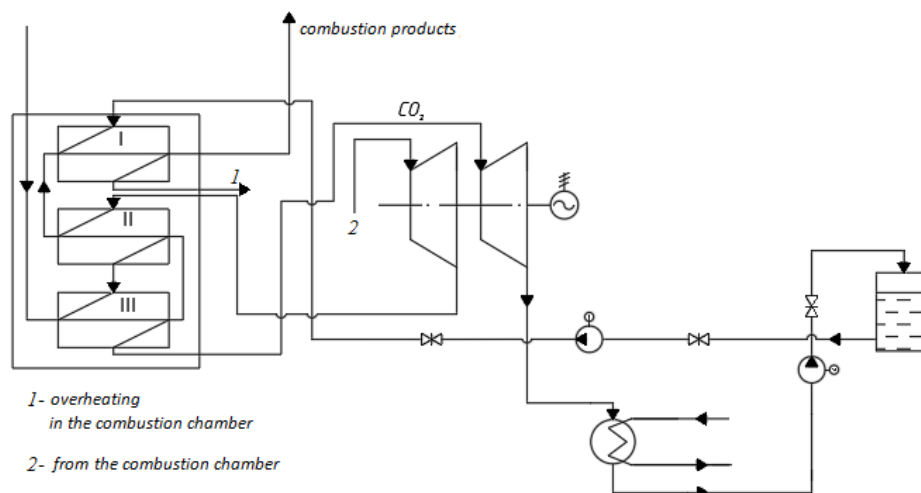

Figure 4. Scheme of double overheating of CO₂ in a gas turbine combustion chamber and a waste heat boiler.

Figure 5 shows the cycles of the settings described.

The cycles consist of the following processes: 12 - 13 - increasing the pressure of liquid CO₂ in the pump 16; 13 - 131 - heating liquid CO₂ to a boiling point in evaporator I; 131 -

132 - isobaric-isothermal process of boiling CO₂ in evaporator I; 13 - 14 - overheating of gaseous CO₂ in the superheater III of the waste heat boiler 27; 14 - 15 — adiabatic expansion of gaseous CO₂ in CVP 28; ; 15 - 16 - the second overheating of gaseous CO₂ in the stage II of the waste heat boiler 27; 16 - 17 - adiabatic expansion of gaseous CO₂ in NPP 29; 17 - 12 - isobaric-isothermal process of condensation of carbon dioxide in a condenser-evaporator 13. For the refrigeration cycle: process 1-2 - adiabatic compression of gaseous CO₂ in the compressor of the first stage; 2-3 - CO₂ cooling in front of the second stage compressor; 3-4 - adiabatic compression of CO₂ in a second stage compressor; 4-5 - intermediate cooling of CO₂ in front of the compressor of the third stage; 5-6 — adiabatic compression of CO₂ in a third stage compressor; 6-7 - cooling and condensation of gaseous CO₂ in the condenser 9; 7-8 - the first adiabatic throttling of liquid carbon dioxide in the inductor 20 into the separator 22; 9-10 - the second adiabatic throttling of CO₂ in the throttle 21 to the separator 23; 11-1 - boiling liquid CO₂ in a condenser-evaporator 13.

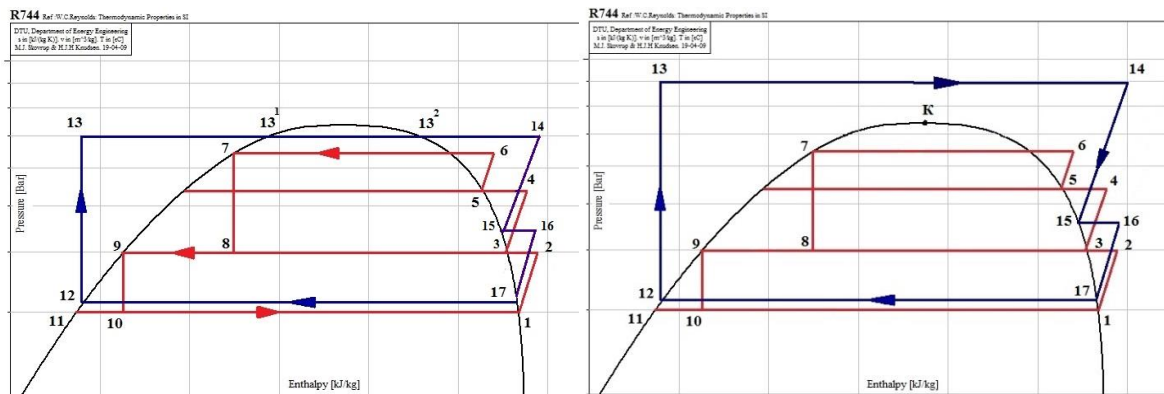

Figure 5. A cycle of a carbon dioxide turboexpander trigeneration unit with double overheating in a waste heat boiler using sub- and supercritical parameters of the working fluid.

3. Thermodynamic calculation:

Specific work of compression of gaseous CO₂ in a three-stage compressor:

$$l_s^k = (h_2 - h_1) + (h_4 - h_3) + (h_6 - h_5).$$

The specific work of the expansion of gaseous CO₂ in a turboexpander:

- for a circuit with a single overheating (Fig. 1):

$$l_s^d = (h_{14} - h_{15}),$$

- for a circuit with a waste heat boiler and double overheating (Fig. 3):

$$l_{s,2}^d = (h_{14} - h_{15}) + (h_{16} - h_{17}).$$

Theoretical (adiabatic) CO₂ compression power in the compressor:

$$N_i^k = G_d^k \cdot l_s^k.$$

Indicator power consumed by the compressor:

$$N_i^k = N_i^k / \eta_i = G_d^k \cdot l_s^k / \eta_i,$$

where η_i – is the indicator compressor efficiency.

Effective power (on a shaft) of the compressor:

$$N_e^k = N_i^k / \eta_M = G_d^k \cdot l_s^k / \eta_i \cdot \eta_M,$$

where η_M – mechanical efficiency of the compressor, taking into account friction.

The electric power consumed by the compressor from the network:

$$N_3^k = N_e^k / \eta_n \cdot \eta_{\text{дог}} = G_d^k \cdot I_s^k / \eta_i \cdot \eta_M \cdot \eta_n \cdot \eta_{\text{дог}},$$

where η_n – transmission efficiency; $\eta_{\text{дв}}$ – The efficiency of the compressor motor.

Electric power received in the turboexpander generator:

- for a circuit with a single overheating (Fig. 1):

$$N_3^d = N_t^d / \eta_i \cdot \eta_M \cdot \eta_n \cdot \eta_e = G_d^d \cdot I_s^d / \eta_i \cdot \eta_M^d \cdot \eta_n \cdot \eta_e,$$

- for a circuit with a waste heat boiler and double overheating (Fig. 3):

$$N_{3,2}^d = N_t^d / \eta_i \cdot \eta_M \cdot \eta_n \cdot \eta_e = G_d^d \cdot I_{s,2}^d / \eta_i \cdot \eta_M^d \cdot \eta_n \cdot \eta_e,$$

where G_d^d – is the actual consumption of CO₂ through the turboexpander; η_r – generator efficiency; - mechanical efficiency of the turboexpander.

The increase in power of the generator due to 2-fold overheating:

$$\Delta N_3 = N_{3,2}^d - N_3^d = G_d^d (I_{s,2}^d - I_s^d) / \eta_i \cdot \eta_M^d \cdot \eta_n \cdot \eta_e,$$

Предлагаемые установки предназначены в основном для производства электроэнергии на собственные нужды, поэтому они должны оцениваться по тому насколько покрываются потребности производства выработанной электроэнергией.

Turbo expander units can also operate in the mode of energy generation (Fig. 1 and Fig. 3), if evaporators are included in the circuits at the first and second stages of the compressor. Thus, cold can be obtained in two evaporators: at a lower temperature level at a boiling point T_{01} in evaporator 25 (Fig. 3) and at a high temperature level at a boiling temperature T_{02} in evaporator 26 (Fig. 3).

The specific mass cooling capacity of the evaporator 25 is defined as:

$$q_{01} = h_{10} - h_1,$$

and evaporator 26 as:

$$q_{02} = h_8 - h_3.$$

The exergy efficiency of the plants is determined by the well-known expression [4]:

$$\eta_e = \frac{\sum E_2}{\sum E_1},$$

where $\sum E_1$ – the sum of the exergies of all flows at the entrance to the installation, and $\sum E_2$ – the sum of the exergies of all useful flows at the exit of the installation [1].

Usefully used exergy streams are understood as electricity, thermal energy and cold.

The incoming flows for the circuit in Figure 1 are the secondary energy flow to the heat supply exchangers 24, 25 Eut.t, the exergy stream to the heat exchanger of the electric power generation circuit of 10 Eut.t. and the coolant flows to the evaporators 27 and 28 Ex.

The incoming exergy flows for the installation (Fig. 3) will be: exergy stream in the $E_{\text{тгТУ}}$ gas turbine, exergy stream in the $E_{\text{ТТ}}$ heat exchanger, exergy stream in the $E_{\text{ТТД}}$ turbine expander and exergy flows in the E_{xl} evaporators.

The exergy exits for the trigeneration plant (Fig. 1) will be:

exergy from the heat supply circuit $E_{\text{теп}}$; exergy obtained in a turboexpander E_{el} ; exergies exiting evaporators 27 and 28 E_{hall} .

The exergy flows for the trigeneration plant (Fig. 3) will be:

exergy obtained in heat exchangers 32, 33 $E_{\text{теп}}$; exergy obtained in turboexpander and in gas turbine $E_{\text{el}}^{\text{TD}}$, $E_{\text{el}}^{\text{GTU}}$; exergies coming out of evaporators 25 и 26 E_{hall} .

Thus, the exergy efficiency of trigeneration plants:

$$\text{- for the circuit in Figure 1: } \eta_e = \frac{\sum E_2}{\sum E_1} = \frac{E_{\text{теп}} + E_{\text{el}} + E_{\text{hall}}}{E_{\text{ТТ}} + E_{\text{ТТД}} + E_{\text{xl}}}$$

$$\text{- for the circuit in Figure 3: } \eta_e = \frac{\sum E_2}{\sum E_1} = \frac{E_{\text{теп}} + E_{\text{el}}^{\text{GTU}} + E_{\text{el}}^{\text{TD}} + E_{\text{hall}}}{E_{\text{ТТ}} + E_{\text{ТТД}}^{\text{GTU}} + E_{\text{ТТД}}^{\text{TD}} + E_{\text{xl}}}$$

An analysis of formulas shows that the exergy efficiency of a CCGT unit with a recovery boiler is greater than the similar efficiency in a circuit with secondary energy resources.

4. Conclusions

The proposed technological schemes of trigeneration plants with a cycle based on carbon dioxide and the production of liquid and gaseous carbon dioxide are one of the solutions to the promising direction of combined energy production and energy saving. The use of trigeneration plants will make it possible to provide a centralized cold supply along with heat and electricity to a specific industrial enterprise, etc., which is one of the promising solutions in the field of energy and competent environmental management.

The use of CO₂ in turboexpander units is relevant and having studied the possibility of operating heat recovery plants for CO₂, we can conclude that the presented trigeneration units based on turboexpander have good potential in reducing enterprises' fuel and energy consumption, as well as reducing thermal pollution of the atmosphere.

5. References

- [1] Agababov V S 2001 *On the use of expander-generator units in the gas industry* (Moscow: Sat. materials of the STC of OAO Gazprom)
- [2] Ovsyannik A V 2012 *Modeling of heat transfer during boiling liquids* (Gomel: GSTU named after P O Sukhoi)
- [3] Bespalov V V, Bespalova V I and Melnikov D V 2017 *Research and optimization of the depth of utilization of flue gas heat in surface heat exchangers* (journal: Thermal Engineering)
- [4] Kudinov A A 2018 *Two-time intermediate overheating of water vapor in the high temperature zone and in the tail of the three-circuit boiler of the utilizer* (journal: Industrial Energy)
- [5] Bespalov V V 2010 *Technology of dehumidification of flue gases from thermal power plants using the heat of condensation of water vapor* (Tomsk: Tomsk Polytechnic University)
- [6] Kudinov A A *Evaluation of the efficiency of CCGT - 800 Kirishskaya SDPP with a three-circuit waste heat boiler* (journal: Energy saving and water treatment)